

Airless Spray Technology

Owner's Manual

For professional Use only

Do not use this equipment before reading this manual!

Airless Sprayer

International Model

**Original instruction
DP6388B**



NOTE: This manual contains important warnings and instructions. Please read and retain for reference



Ningbo Dino-power Machinery Co.,Ltd www.dpairless.com
#606 Guangbo Lijing Center, Tiantong S.Rd, Yinzhou District, Ningbo, China

Table of Contents

Safety Precautions.....	2
General Description.....	4
Technical Parameter.....	4
Operation.....	4
Setup.....	4
Preparing to Paint.....	5
Painting.....	5
Electronic Pressure Control Indicators.....	5
Pressure Relief Procedure.....	6
Spraying.....	6
Spraying Technique.....	6
Practice.....	7
Shutdown and Cleaning.....	7
Troubleshooting.....	8
Parts Listings.....	10
Main Assembly.....	10
Motor Assembly.....	11
Gear Box Assembly.....	12
Suction Set Assembly.....	12
Stand Assembly.....	12
Fluid Section Assembly.....	13
Tip Selection.....	14
Selecting Tip Hose Size.....	14
Choosing The Correct Tip.....	14
Tip Hose Size.....	14
Fan width.....	14
Understanding Tip Number.....	14
Reversible Tip Selection Chart.....	15

Safety Precautions

This manual Contains Information that must be read and understood before using the equipment, When you come to an area that has one of the following symbols, pay particular attention and make certain to heed the safeguard.



This Symbol indicates a potential hazard that may cause serious injury or loss of life. Important safety information will follow.



This symbol indicates a potential hazard to you or to the equipment. Important information that tells how to prevent damage to the equipment or how to avoid causes of minor injuries will follow.

NOTE: Notes give important information which should be given special attention.



Airless units develop extremely high spraying pressures.



- Never put your fingers, hands or any other parts of the body in to the spray jet.
- Never point the spray gun at yourself or anybody else.
- Never use the spray gun without the safety guard.

Attention! Danger of injury by injection!

In case of injury to skin caused by coating materials or solvents consult a doctor immediately. Inform the doctor of the type of coating material or cleaning agent with which the injury was caused.

The operating instructions state that the following points must always be observed before starting up:

1. Faulty units should not be used.
2. Secure spray gun using the safety catch on the trigger
3. Ensure that the unit is properly earthed.
4. Check the permissible operating pressure.
5. Check all connections for leaks.

The instructions regarding regular cleaning and maintenance of the unit must be strictly observed. Before any work is done on the unit or for every break in work the following rules must be observed:

1. Release the pressure from the spray gun and hose.
2. Secure the spray gun using the safety catch on the trigger.
3. Turn off the motor.

Be safety-conscious!

All local regulation in force must be observed. In order to ensure safe operation of the airless systems the safety regulations listed below must be followed:

1. In order to avoid dangers, read the operating instructions carefully and follow the instructions laid down in them.
2. Do not use materials with flash point below 21 °C (70 °F).
3. The use of this unit is prohibited in workshops which are covered under the explosion prevention regulations.
4. Never spray near sources of ignition; e.g. open flames, cigarettes also cigars and pipes are sources of ignition - sparks, hot wires and hot surfaces, etc.
5. Attention! Danger of injury by injection!
Never point the spray gun at yourself or anyone else. Never put your fingers or hands into the spray jet. The very high spraying pressures can cause very serious injuries. Never use the spray gun without the safety guard.



When installing and removing the tip and during breaks in work the spray gun must always be secured, so that it cannot be activated.

6. Wear respiratory equipment when spraying. The operator must be provided with a protective mask.
In order to prevent work related illness, the manufacturer's agents used must be observed when preparing, working with and cleaning the unit. Protective clothing, gloves and in certain cases, protective skin cream are necessary to protect the skin.
7. The spray gun and high pressure hose between the unit and spray gun must be of a sufficient standard for the pressure produced in the unit.
The permissible operating pressure for the high-pressure hose, the manufacturer and the date of manufacture must be indicated by a permanent identification marking on the hose. Furthermore, it must be constructed so that the electrical resistance between the connections to the unit and the spray gun is equal to or less than one megohm.
8. Under certain conditions the follow speed can cause an electrostatic charge on the unit. This could cause sparks or flames on discharging. It is, therefore, important that the unit is always earthed over the electrical installation. The contact should be made using a shockproof socket earthed in accordance with the regulations.
9. Forbidden to use of electrostatic atomising and spraying equipment with machines not specifically designed for this equipment, because it may result in serious hazards for the operators;
10. Pay attention to hazards resulting from contact with and/or breathing of toxic materials, gases, mists and vapours which may be created by operation of the machine.
11. Before installation and usage, visually inspection for damage on hoses which may be subjected to friction should be done.

9. Attention! Please observe the following when working inside and outside:
No Solvent Gasses Should be carried to the unit. No solvent gasses should be near the unit. Set up the unit on the opposite side to the object being Sprayed. When spraying out doors, take the wind direction in to account. When working in doors there must be sufficient ventilation to ensure that the solvent gasses are carried away. A minimum distance of 6.1m(20') must be observed between the unit and object being sprayed.
10. Extraction equipment Should be installed by the user in accordance with the local regulations.
11. The objects being sprayed must be earthed.
12. When cleaning the unit, solvent should never be sprayed into a container with only a small opening(bunghole). An explosive gas/air mixture is likely to form. The container must be earthed.
13. Cleaning the unit.
A harsh jet should never be used to spray the unit. In particular a high-pressure cleaner or high-pressure steam cleaner should never be used. There is a danger that water will penetrate into the unit and cause a short-circuit.
14. Pulling the trigger causes a recoil force to the hand that is holding the spray gun.
The recoil force of the spray gun is particularly powerful when the tip has been removed and a high pressure has been set on the airless high-pressure pump. Therefore, when cleaning without tip set the pressure control valve to the lowest pressure.
15. The mains plug should only be disconnected from the socket when work is being carried out on the electrical components.
14. Work or repairs should only be carried out on electrical equipment by a trained electrician, even if the work is described in the operating instructions. No liability will be accepted for incorrectly installed electrics.
15. Positioning when the ground is uneven.
The front of the unit must point downward so that the machine does not slip away.

HAZARD: INJECTION INJURY- A high pressure stream of paint produced by this equipment can pierce the skin and underlying tissues, leading to serious injury and possible amputation.

DO NOT TREAT AN INJECTION INJURY AS A SIMPLE CUT! Injection can lead to amputation. See an physician immediately.

PREVENTION:

- The maximum operating range of the unit is 221 BAR (3200 PSI) fluid pressure.
- Never aim the gun at any part of the body.
- Never allow any part of the body to come in contact with stream created by a leak in the fluid hose.
- Never Put your hand in front of the gun. Gloves will not provide protection against and injection injury.
- ALWAYS lock the gun trigger, shut the fluid pump off and release all pressure before servicing, cleaning the tip guard, changing tips, or leaving unattended. Pressure will not be released by turning off the engine. The PRIME/SPRAY knob must be turned to PRIME to relieve the pressure. Refer to the PRESSURE RELIEF PROCEDURE described in this manual.
- The tip guard must always be in place while spraying. The tip guard provides some protection against injection injuries but is mainly a warning device.
- ALWAYS remove the spray tip before flushing or cleaning the system.
- The paint hose can develop leak from wear, kinking and abuse. A leak is capable of injecting material into the skin. Inspect the paint hose before each use.

NOTE TO PHYSICIAN:

Injection into the skin is a traumatic injury. It is important to treat the injury surgically as soon as possible. DO NOT delay treatment to research toxicity. Toxicity is a concern with some coatings injected directly into the blood stream. Consultation with a plastic surgeon or reconstructive hand surgeon may be advisable.

HAZARD: EXPLOSION OR FIRE-Solvent and paint fumes can explode or ignite, causing property damage and/or severe injury.

PREVENTION:

- Fire extinguishing equipment must be present and in good working order.
- Use only conductive or earthed high pressure fluid hoses for airless applications, be sure that the gun is earthed properly through hose connections.
- The pump must be connected to an earthed object. Use the green earthing wire to connect the pump to a water pipe, steel beam, or other electrically earthed surface.
- When flushing equipment use the lowest possible pressure.

HAZARD: EXPLOSION HAZARD DUE TO INCOMPATIBLE MATERIALS- May cause property damage or severe injury.

PREVENTION:

- Do not use bleach.
- Do not use halogenated hydrocarbon solvents such as methylene chloride and 1,1,1-trichloroethane. They are not compatible with aluminum and may cause an explosion. If you are unsure of a material's compatibility with aluminum, contact your coating's supplier.

HAZARD: GENERAL-May cause property damage or severe injury.

PREVENTION:

- This high pressure airless pump is designed to be used with manufacturer authorized parts only. When using this pump with parts that do not comply with the minimum specifications and safety devices of the pump manufacturer, the user assumes all risks and liabilities.
- Before each use, check all hoses for cuts, leaks, abrasion or bulging of cover, as well as damage or movement of couplings. If you any of these condition exist, replace the hose immediately. Never repair a paint hose. Replace it with another earthed hose.
- Wear protective eyewear.
- Do not spray on windy days.

Earthing Instructions

This product must be earthed. In the event of an electrical short circuit, earthing reduces the risk of electric shock by providing an escape wire for the electric current. This product is equipped with a cord having an earthing wire with an appropriate earthing plug. The plug must be plugged into an outlet that is properly installed and earthed in accordance with all local codes and ordinances.

DANGER-Improper installation of the earthing plug can result in a risk of electric shock.

If repair or replacement of the cord or plug is necessary, do not connect the green earthing wire to either flat blade terminal. The wire with insulation having a green outer surface with or without yellow stripes is the earthing wire and must be connected to the earthing pin.

Check with a qualified electrician or serviceman if the earthing instructions are not completely understood, or if you are in doubt as to whether the product is properly earthed. Do not modify the plug provided. If the plug will not fit the outlet, have the proper outlet installed by a qualified electrician.

General Description

This airless sprayer is a precision power tool used for spraying many types of materials. Read and follow this instruction manual carefully for proper operating instructions, and safety information.

The paint sprayer is compatible with the following water soluble paints: phenol aldehyde paint series -nitryl paint series alkyd paint series epoxy resin paint series oxidized rubber paint series latex paint series etc.



Technical Parameter

Working pressure range	0-2800 psi(0-19MPa,0-193 bar)
Electric motor	6.0A (open frame, universal)
Operating horsepower	1/2 hp 375w
Maximum delivery (with tip)	0.25gpm (1.0 lpm)
Paint Hose	1/4 in x 25 ft (6.4 mm x 7.5m)
Maximum Tip hole size	0.015 in. (0.38mm)
Weight, sprayer only	16 lb (7.3 kg)
Weight, sprayer, hose & gun	19.2 lb (8.7 kg)
Dimensions(upright):	
Length	14.5in (36.8cm)
Width:	12.4in (31.5cm)
Height:	17.9in (45.5cm)
Dimensions(Folded):	
Length:	19.3in (49.0cm)
Width:	15.3in (38.9cm)
Height:	29.2in (74.2cm)
Power Cord:	18AWG, 3 wire, 6ft(1.8m)
Fluid inlet fitting	3/4in. internal thread (Standard garden hose thread)
Fluid outlet fitting	1/4NPSM external thread
Inlet screen (on suction tube)	35mesh (450 micro)
Wetted parts, pump & hose	Stainless steel, brass, leather, ultra-high molecular weight polyethylene (UHMWPE), carbide, nylon, aluminum, PVC, polypropylene, fluoroelastomer
Wetted parts, gun	Aluminum, brass, carbide, nylon, plated steel, stainless steel, UHMWPE, zinc
Generator requirement	1500 Watt minimum
Electrical power requirement	230V 50Hz, 15A 1 phase
Storage temperature range	-30° to 160°F (-35° to 71° C)
Operating temperature range	40° to 115°F (4° to 46° C)
Maximum allowable pressure for the coating material (MPa)	
Maximum allowable temperature of the coating material(°C)	
Typical coating material flow rate(l/min)	
Sound power level (LWA 4m hemisphere) dB(A)	97.9
Sound pressure level(LpA Airborne noise 1m away from working station) dB(A)	90
Uncertainty dB(A)	1.5
Vibration valve for spraying gun(m/s ²)	2.391
Uncertainty(m/s ²)	0.5

Operation:

WARNING

This equipment produces a fluid stream at extremely high pressure. Read and understand the warnings in the safety precautions section at the front of this manual before operating this equipment.

Setup

Perform the following procedure before plugging in the power cord of an electric unit.

- 1.Ensure that the suction set and the return hose are attached and secure.
- 2.Using a wrench, attach a minimum of 7.5m 24.6' x 10mm (1/4") nylon airless spray hose to the unit. Tighten securely.
- 3.attach an airless spray gun to the spray hose. Using two wrenches (one on the gun and one on the hose), tighten securely.

NOTE: Do not attach the tip to the spray gun yet. Remove the tip if it is already attached.

WARNING

Make sure all airless hoses and spray guns are electrically grounded and rated for at least 228 bar (3300 psi) fluid pressure.

- 4.Make sure the pressure control knob is in its OFF position
- 5.Make sure the ON/OFF switch is in its OFF position.
- 6.Fill the oil cup with 15g (one tablespoon) of piston seal lubricant (piston lube).

CAUTION

Never operate unit for more than ten seconds without fluid. Operating this unit without fluid will cause unnecessary wear to the packing.

- 7.Make sure the electrical service is correct for the unit.
- 8.Plug the power cord into a properly grounded outlet at least 7.6m (25') from the spray area.

CAUTION

Always use a minimum 12 gauge, three-wire extension cord with a grounded plug. Never remove the third prong or use an adapter.

Preparing a New Sprayer

If this unit is new, it is shipped with test fluid in the fluid section to prevent corrosion during shipment and storage. This fluid must be thoroughly cleaned out of the system with mineral spirits before you begin spraying.

CAUTION

Always keep the trigger lock on the spray gun in the locked position while preparing the system.

- 1.Place the suction tube into a container of mineral spirits that has a flash point of 60°C (140°F) or above.
- 2.Place the return hose into a metal waste container.
- 3.Turn Pressure Control Knob all the way left (counter-clockwise) to minimum pressure.



- 4.Move the PRIME/SPRAY valve down to the PRIME position.
- 5.Turn the unit on by moving the ON/OFF switch to the On position.
- 6.Allow the Sprayer to run for 15-30 seconds to flush the test fluid out through the return hose and into the waste container.
- 7.Turn the unit off by moving the ON/OFF switch to the OFF position.

Preparing to Paint

Before painting, it is important to make sure that the fluid in the system is compatible with the paint that is going to be used.

NOTE: Incompatible fluid and paint may cause the valves to become stuck closed, which would require disassembly and cleaning of the sprayer's fluid section.

CAUTION

Always keep the trigger lock on the spray gun in the locked position while preparing the system.

1. place the suction tube into a container of the appropriate solvent for the material being sprayed (refer to recommendations of the material manufacture). An example of the appropriate solvent is water for latex paint.
2. place the return hose into a metal waste container.
3. set the pressure to minimum by turning the pressure control knob all the way left (counter-clockwise) to minimum pressure.
4. move the PRIME/SPRAY valve down to the PRIME position.
5. Turn the unit on by moving the ON/OFF switch to the ON position.
6. Allow the sprayer to run for 15-30 seconds to flush the old solvent out through the return hose and in to the metal waste container.



7. Turn the unit off by moving the ON/OFF switch to the OFF position.

NOTE: Make sure that the spray gun does not have a tip or tip guard installed.

8. Move the PRIME/SPRAY valve up to the SPRAY position.
9. Turn the unit on.
10. Unlock the gun by turning the gun trigger lock to the unlocked position.

WARNING

Ground the gun by holding it against the edge of the metal container while flushing. Failure to do so may lead to a static electric discharge, which may cause a fire.

11. Trigger the gun into the metal waste container until the old solvent is gone and fresh solvent is coming out of the gun.
12. Lock the gun by turning the gun trigger lock to the locked position.
13. Set down the gun and increase the pressure by turning the pressure control knob slowly clockwise into the high pressure spray.
14. Check the entire system for leaks. If leaks occur, follow the Pressure Relief Procedure in this manual before tightening any fittings or hoses.
15. Follow the "Pressure Relief Procedure" in this manual before changing from solvent to paint.



Trigger lock in locked position

WARNING

Be sure to follow the pressure relief procedure when shutting the unit down for any purpose, including servicing or adjusting any part of the spray system, changing or cleaning spray tips, or preparing for cleanup.

Painting

1. Place the suction tube into a container of paint.
2. Place the return hose into a metal waste container.
3. Set the pressure to minimum by turning the pressure control knob to the Min setting in the low pressure spray.
4. Move the PRIME/SPRAY valve down to the PRIME position.
5. Turn the unit on by moving the ON/OFF switch to the ON position.
6. Allow the sprayer to run until paint is coming through the return hose into the metal waste container.
7. Turn the unit off by moving the ON/OFF switch to the OFF position.
8. Remove the return hose from the waste container and place it in its operating position above the container of paint.
9. Move the PRIME/SPRAY valve up to the Spray position.
10. Turn the unit on.
11. Unlock the gun by turning the gun trigger lock to the unlocked position.

WARNING

Ground the gun by holding it against the edge of the metal container while flushing. Failure to do so may lead to a static electronic discharge, which may cause a fire.



12. Trigger the gun into the metal waste container until all air and solvent is flushed from the spray hose and paint is flowing freely from the gun.
13. Lock the gun by turning the gun trigger lock to the locked position.
14. Turn the unit off.
15. Attach tip guard and tip to the gun as instructed by the tip guard or tip manuals.



Trigger lock in locked position

WARNING

POSSIBLE INJECTION HAZARD. Do not spray without the tip guard in place. Never trigger the gun unless the tip is in either the spray or the unclog position. Always engage the gun trigger lock before removing, replacing or cleaning tip.

16. Turn the unit on.
17. Increase the pressure by turning the pressure control knob slowly clockwise toward the high pressure spray and test the spray pattern on a piece of cardboard. Adjust the pressure control knob until the spray from the gun is completely atomized. Try to keep the pressure control knob at the lowest setting that maintains good atomization.

Note: Turning the pressure up higher than needed to atomize the paint will cause premature tip wear and additional overspray

Pressure Relief Procedure



Be sure to follow the pressure relief procedure when shutting the unit down for any purpose, including servicing or adjusting any part of the spray system, changing or cleaning spray tips, or preparing for clean up.

1. Lock the gun by turning the gun trigger lock to the lock position.
2. Turn the unit off by moving the ON/OFF switch to the OFF position.
3. Turn the pressure control knob counterclockwise to its OFF position.
4. Unlock the gun by turning the gun trigger lock to the unlocked position.
5. Hold the metal part of the gun firmly to the side of a metal container to ground the gun and avoid a build up of static electricity.
6. Trigger the gun to remove any pressure that may still be in the hose.
7. Lock the gun by turning the gun trigger lock to the locked position.
8. Move the PRIME/SPRAY valve down to the PRIME position.



Trigger lock in locked position



Spraying



POSSIBLE INJECTION HAZARD. Do not spray without the tip guard in place. Never trigger the gun unless the tip is in either the spray or the unclog position. Always engage the gun trigger lock before removing, replacing, or cleaning tip.

Spraying Technique

The following techniques, if followed, will assure professional painting results. Hold the gun perpendicular to the surface and always at equal distance from the surface. Depending on the type of material, surface, or desired spray pattern, the gun should be held at a distance of 30 to 50 cm (12 to 14 inches). Move the gun either across or up and down the surface at a steady rate. Moving the gun at a consistent speed conserves material and provides even coverage. The correct spraying speed allows a full, wet coat of paint to be applied without runs or sags. Holding the gun closer to the surface deposits more paint on the surface and produces a narrow spray pattern. Holding the gun farther from the surface produces a thinner coat and wide spray pattern. If runs, sags, or excessive paint occur, change to a spray tip with a smaller orifice. If there is an insufficient amount of paint on the surface or you desire to spray faster, a larger orifice tip should be selected. Maintain uniform spray stroke action, Spray alternately from left to right and right to left. Begin movement of the gun before the trigger is pulled.

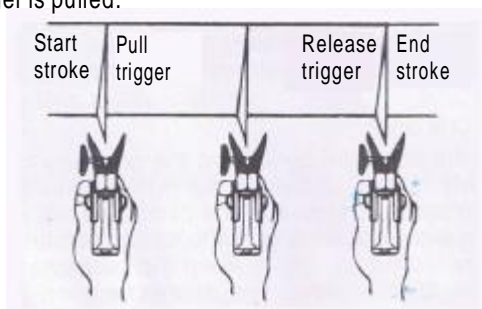

Avoid arcing or holding the gun at an angle, This will result in an uneven finish.

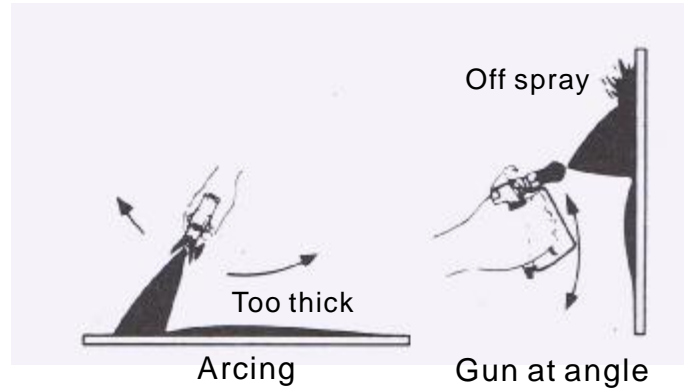

Proper lapping (overlap of spray pattern) is essential to an even finish. Lap each stroke. If you are spraying horizontally, aim at the bottom edge of the preceding stroke, so as to lap the previous pattern by 50%.

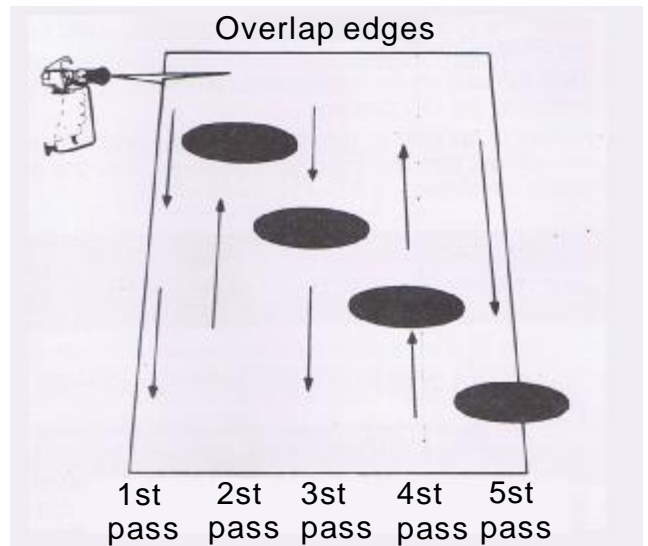

For corners and edges, split the center of the spray pattern on the corner or edge and spray vertically so that both adjoining sections receive approximately even amounts of paint.

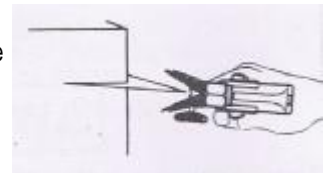

When spraying with a shield, hold it firmly against the surface. Angle the spray gun slightly away from the shield and toward the surface. This will prevent paint from being forced underneath. Shrubs next to houses should be tied back and covered with a canvas cloth. The cloth should be removed as soon as possible. Our gun extensions are extremely helpful in these situations. Nearby objects such as automobiles, outdoor furniture, etc. should be moved or covered whenever in the vicinity of a spray job. Be careful of any other surrounding objects that could be damaged by overspray.

PRACTICE

1. Be sure that the paint hose is free of kinks and clear of objects with sharp cutting edges.
2. Turn the pressure control knob counterclockwise to its lowest setting.
3. Turn the PRIME/SPRAY valve up to its SPRAY position.
4. Turn the pressure control knob clockwise to its highest setting. The paint hose should stiffen as paint begins to flow through it.
5. Unlock the gun trigger lock.
6. Trigger the spray gun to bleed air out of the hose.
7. When paint reaches the spray tip, spray a test area to check the spray pattern.

Use the lowest pressure setting necessary to get a good spray pattern. If the pressure is set too high, the spray pattern will be too light. If the pressure is set too low, tailing will appear or the paint will spatter out in gobs rather than in a fine spray.

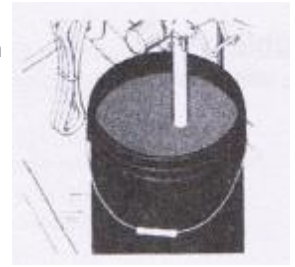
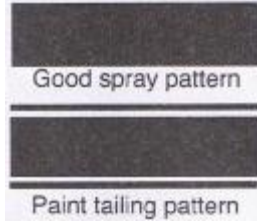

7. Submerge suction tube in water or flushing solvent.

8. Turn pressure control knob to the PRIME/CLEAN setting.



9. Turn the power switch ON.



10. Flush until approximately 1/3 of the flushing fluid is emptied from the pail.



11. Turn power switch OFF.

Shutdown and Cleaning

1. Pressure Control Knobs Settings
2. Remove tip and guard assembly from gun and place in flushing fluid.
3. Lift suction tube and prime tube from paint pail. Let them drain into paint pail for a while.

4. Separate prime tube (smaller) from suction tube (larger)

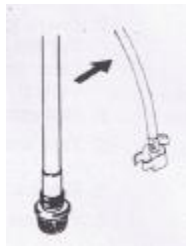

5. Place empty waste and water or solvent pails side by side.



6. Place prime tube in waste pail.



When storing the paint station for 16 hours or more, a thorough cleaning is recommended:

1. shutdown paint sprayer
2. thoroughly clean paint sprayer and station according instruction;
3. be sure that machine and tubes are clear any water or fluid as these may freeze;
4. Coil high pressure hose and store on back of tool with hook and loop straps;
5. Store filter spraying gun, and sprayer in plastic bag and seal;

Troubleshooting

Problem	Cause	Solution
The unit will not run	<ol style="list-style-type: none"> 1.The unit is not plugged in 2.Tripped breaker 3.The pressure is set too low(pressure control knob set at minimum setting does not supply power to unit) 4.Faulty or loose wiring. 5.Excessive motor temperature. 6.ON/OFF switch is defective. 	<ol style="list-style-type: none"> 1.Plug the unit in 2.Reset the breaker. 3.Turn the pressure control knob clockwise t supply power to the unit and increase the pressure setting. 4.Inspect or take to a authorized service center. 5.Allow motor to cool. 6.Replace the ON/OFF switch.
The unit will not prime.	<ol style="list-style-type: none"> 1.The PRIME/SPRAY valve is in the SPRAY position 2.Air leak in the position tube/suction set. 3.The siphon tube filter and /or inlet screen is clogged. 4.The siphon tube/suction set is clogged. 	<ol style="list-style-type: none"> 1.Rotate the PRIME/SPRAY valve clockwise to the PRIME position. 2.Check the siphon tube/suction set. Connection and tighten or re-tape the connection with Teflon tape. 3.Remove the inlet screen and clean. Remove the siphon tube/suction set and clean.
The unit will not build or maintain pressure	<ol style="list-style-type: none"> 1.The spray tip is worn. 2.the Spray tip is too large 3.The pressure control knob is not set properly 4.The pump filter ,gun filter, or inlet screen is clogged. 5.Material flows form the return hose when the PRIME/SPRAY valve is in the SPRAY position. 6.There is external fluid leak. 7.Air leak in the siphon tube/suction set. 8.There is an internal fluid section leak (packings are worn and/or dirty, valve balls are worn). 9.Worn valve seats. 10.Motor power but fails to rotate. 	<ol style="list-style-type: none"> 1.Replace the spray tip following the instruction that came with the spray gun. 2.Replace the spray tip with a tip that has a smaller orifice following the instructions that came with the spray gun. 3.Turn the pressure control knob clockwise to increase the pressure setting. 4.Remove the pump filters element and clean. Remove the gun filter and clean. Remove the inlet screen and clean. 5.Clean or replace the PRIME/SPRAY valve. 6.Check the siphon tube/suction set connection and tighten or re-tape the connction with Teflon Tape. 7.Check for external leaks at all connections. Tighten connections, if necessary. 8.Clean the valves and service the fluid section. 9.Reverse or replance the valve seats. 10.Take unit to authorized service center.
Fluid leakage at the upper end of the fluid section.	<ol style="list-style-type: none"> 1.The upper packings are worn. 2.The piston rod is worn. 	<ol style="list-style-type: none"> 1.Repack the pump following this manual . 2.Replace the piston rod.

Troubleshooting

Problem	Cause	Solution
Excessive surge at the spray gun.	<ol style="list-style-type: none">1. Wrong type of airless spray hose.2. The Spray tip worn or too large.3. Excessive pressure.	<ol style="list-style-type: none">1. Replace hose with a minimum of 5m (50")X10mm(1/4") ground textiled braid airless paint spray hose.2. Replace the spray tip following the instructions that came with the spray gun.3. Rotate the pressure control knob counterclockwise to decrease spray pressure.
Poor spray pattern.	<ol style="list-style-type: none">1. The spray tip is too large for the material being used.2. Incorrect pressure setting.3. The material being sprayed is too viscous.	<ol style="list-style-type: none">1. Replace the spray tip with a new or smaller spray tip following the instructions that came with the spray gun.2. Rotate the pressure control knob to adjust the pressure for a proper spray pattern.3. Add solvent to the material according to the manufactures recommendations.
The unit lacks power.	<ol style="list-style-type: none">1. The pressure adjustment is too low.2. Improper voltage supply.	<ol style="list-style-type: none">1. Rotate the pressure control knob clockwise to increase the pressure setting.2. Connect the input voltage to the proper voltage for the unit.

Parts List Main Assembly

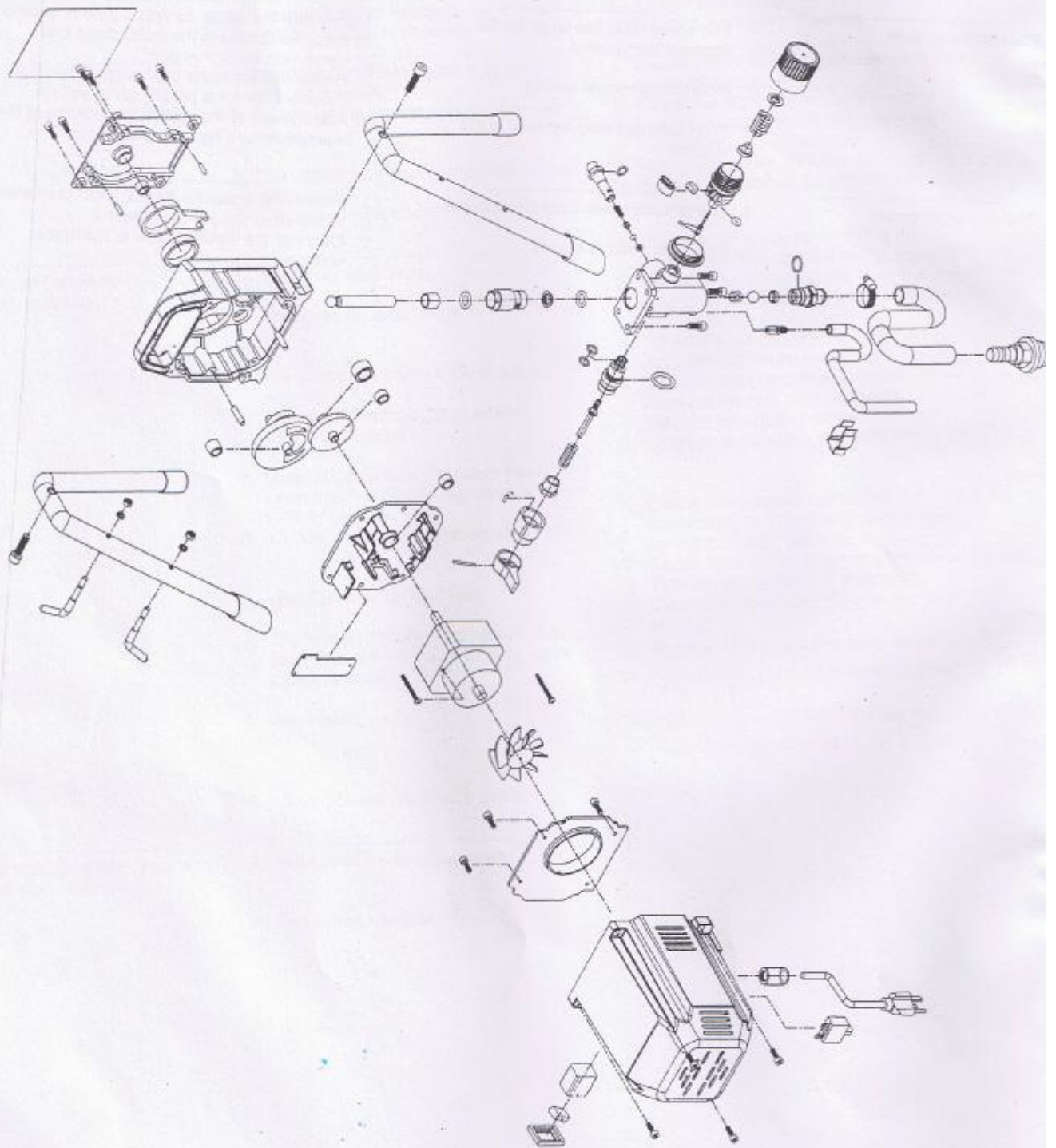

Motor Assembly

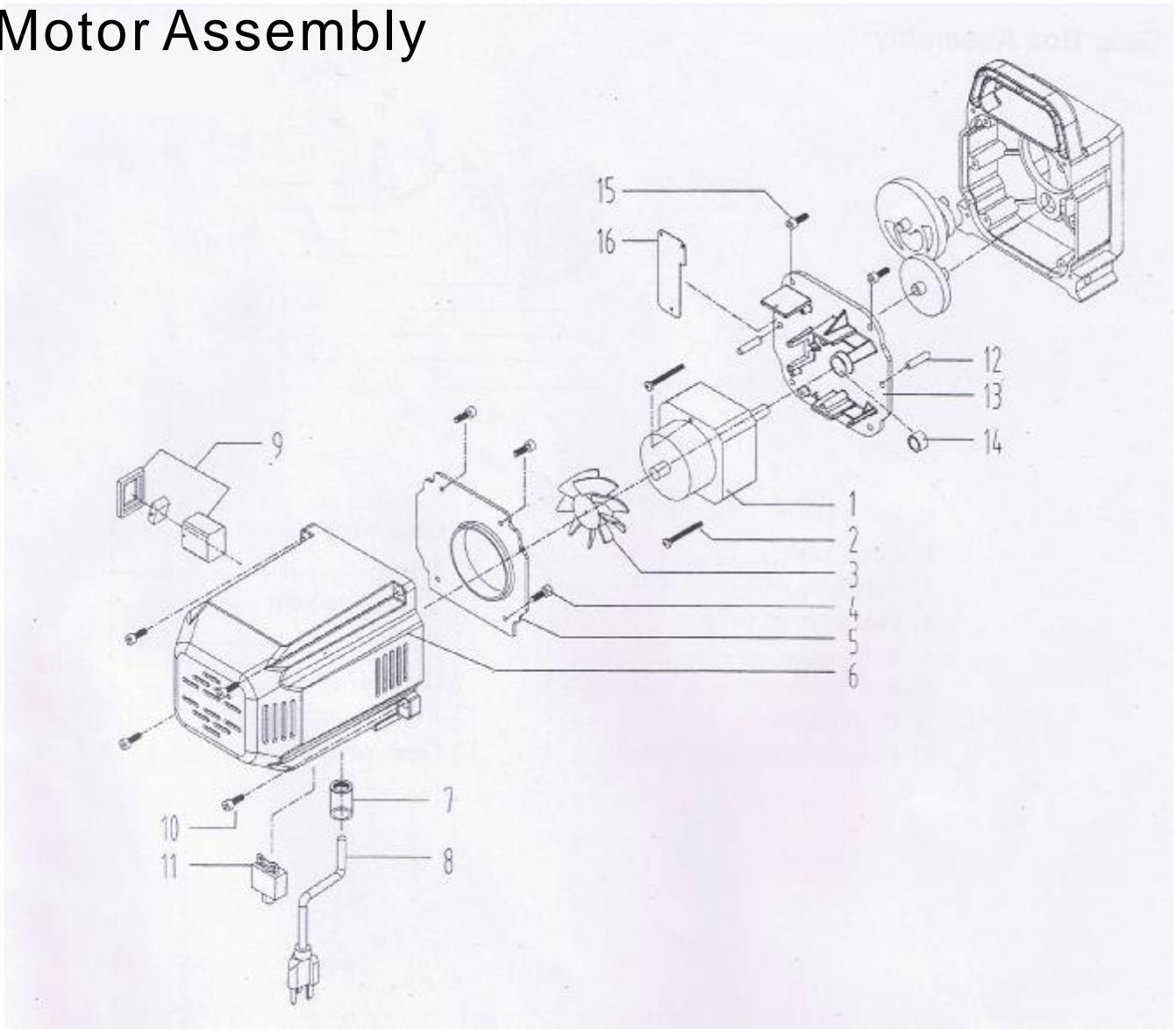

Motor Assembly

1.Motor.....	1	9.ON/OFF switch.....	1
2.Screw.....	2	10.Screw.....	4
3.Motor fan.....	1	11.Circuit breaker.....	1
4.Screw.....	4	12.Pin.....	2
5.Gasket.....	1	13.Motor holder.....	1
6.Motor cover labels.....	1	14.Couper oring.....	1
7.Strain relief.....	1	15.Screw.....	4
8.Power cord.....	1	16.Electric main board.....	1

Gear Box Assembly

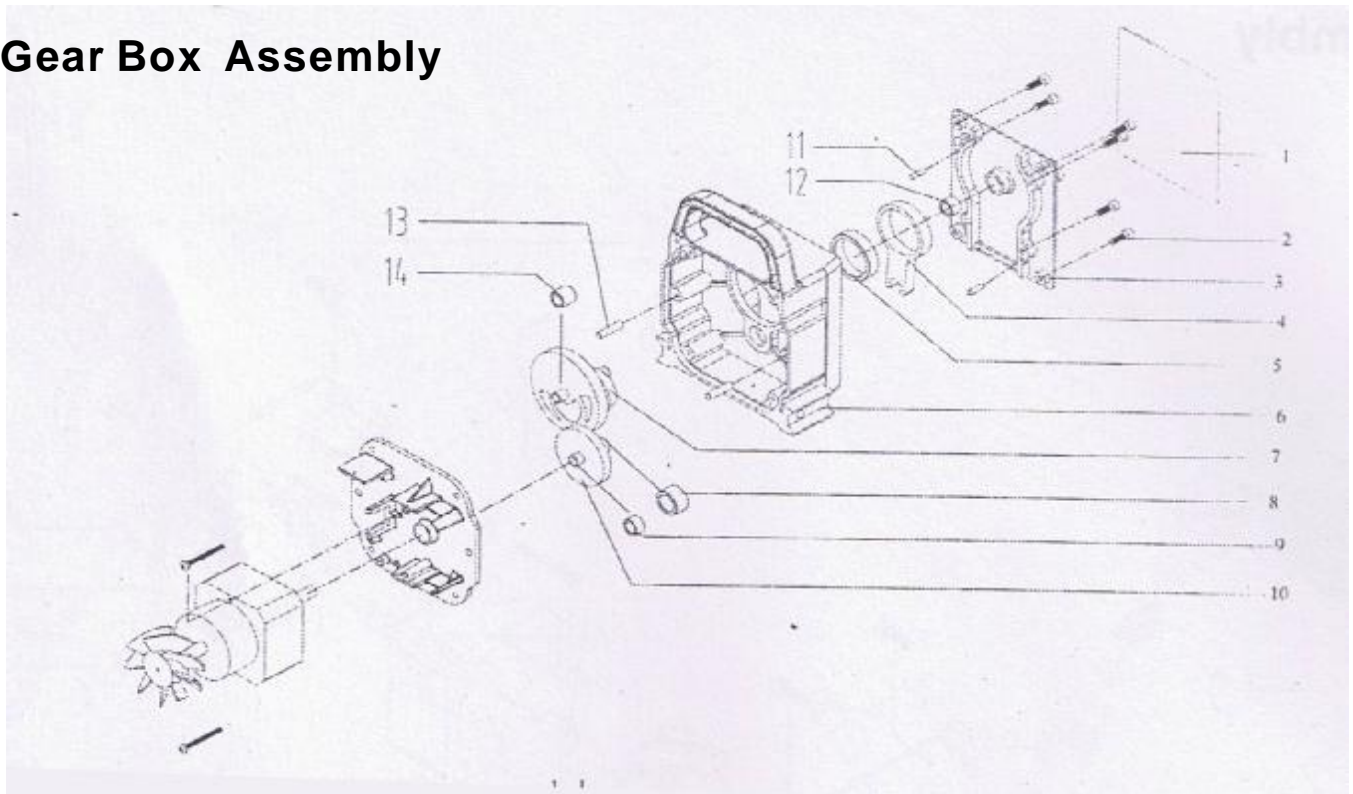

Gear Box Assembly

1.Cover laber.....	1	8.Gear wrap.....	1
2.Screw.....	8	9.Wrap.....	1
3.Front cover w/label.....	1	10.2nd stage gear.....	1
4.Rod.....	1	11.Pin.....	1
5.Rod couper o-ring.....	1	12.Gear wrap.....	2
6.Pump housing.....	1	13.Pin.....	2
7.Crankshaft/gear assembly.....	1	14.Gear wrap.....	1

Suction Set Assembly

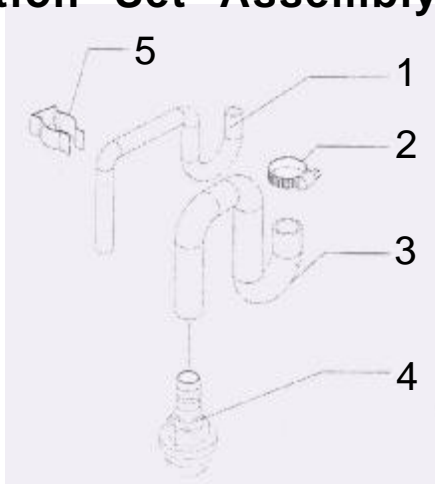

Suction Set Assembly

1.Return tube assembly.....	1
2.Retaining Clip.....	1
3.Siphon hose.....	1
4.Inlet screen.....	1
5.Clip.....	1

Stand Assembly

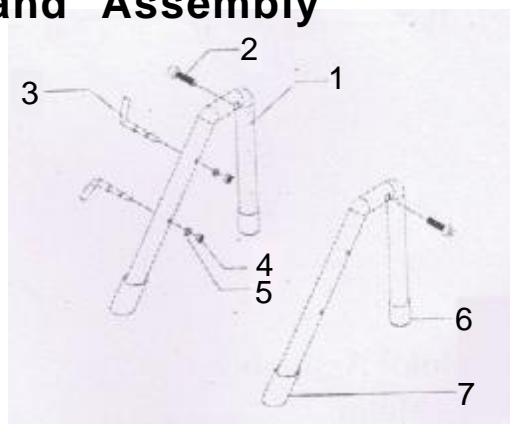

Stand Assembly

1.Leg.....	2
2.Screw.....	2
3.Cord wrap.....	2
4.Nut.....	2
5.Mater washer.....	2
6.Drip cup.....	2
7.Drip cup2.....	2

22. Coupler.....	1
23. Spring.....	1
24. Holder H Needle.....	1
25. Shell.....	1
26. Spring.....	1
27. Ball.....	1
28. Allg Slice.....	1
29. O-ring.....	1
30. Connector.....	1
31. O-ring, Viton.....	1
32. O-ring, Teflon.....	1
33. Gasket.....	1
34. Valve Housing.....	1
35. Valve Stem.....	1
36. Spring.....	1
37. Valve Retainer.....	1
38. Cam base.....	1
39. Valve Handle.....	1
40. Pin.....	1
41. Groove Pin.....	1
42. Fitting.....	1

NOTE: When Using “HOT” solvents, replace Viton O-ring (item 32) with optional Teflon o-ring install with o-ring tool

Tip Selection

Selecting Tip Hole Size

Tips come in a variety of hole sizes for spraying a range of fluids. Your sprayer includes an 0.015 in (0.38mm) tip for use in most spraying applications. Use the following table to determine the range of recommended tip hole sizes for each fluid type. If you need a tip other than the one supplied, see the **Reversible tip Selection Chart** on page 15.

HINTS:

- As you spray, the tip wears and enlarges, Starting with a tip hole size smaller than the maximum will allow you to spray within the rated flow capacity of the sprayer.
- Maximum tip hole sizes supported by the sprayer. 0.015om (0.38mm)

Tip Hole Size	Coatings				
	Stains	Enamels	Primers	Interior Paints	Exterior Paints
0.011 in.(0.28mm)	✓				
0.013 in.(0.33mm)	✓	✓	✓	✓	
0.015 in.(0.38mm)		✓	✓	✓	✓
0.017 in.(0.43mm)			✓	✓	✓
0.019 in.(0.48mm)					✓

Choosing The Correct Tip

Consider Coating and Surface to be Sprayed. Make sure you use best tip hole size for that coating and best fan width for that surface.

Tip Hole Size

Tip hole size controls flow rate the amount of paint that comes out of the gun.

HINTS:

- Use large tip hole size with thicker coatings and smaller tip hole sizes with thinner coatings.
- Maximum tip hole sizes supported by sprayer: 0.015 in. (0.38mm)
- Tip wear with use and need periodic replacement.

Fan Width:

Fan width is the size of the spray pattern, which determines the area covered with each stroke. Narrower fans deliver a thicker coat, and wider fans deliver a thinner coat.

HINTS:

- Select a fan width best suited to the surface being sprayed.
- Wider fans allow provide better coverage on broad, open surfaces.
- Narrower fans provide better control on small, confined surfaces.

Understanding Tip Number

The Last Three digits of tip number (i.e.:221413) Contain information about hole size and fan width on surface when gun is held 12 in. (30.5cm) from surface being sprayed.

First digit when doubled = approximate fan width

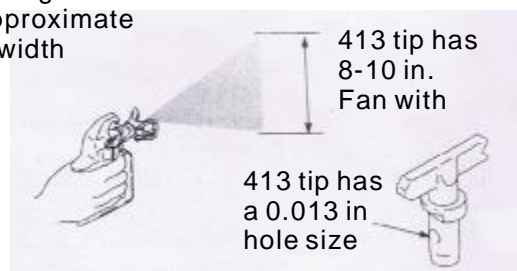

Last two digits= tip hole size in thousands of an inch

Reversible Tip Selection Chart

Tip Part No:	Fan Width 12 in (305 mm) from surface	Hole Size
Alt311	6-8 in. (152-203mm)	0.011 in. (0.28mm)
Alt411	8-10 in. (203-254mm)	0.011 in. (0.28mm)
Alt313	6-8 in. (152-203mm)	0.013 in. (0.33mm)
Alt413	8-10 in. (203-254mm)	0.013 in. (0.33mm)
Alt415	8-10 in. (203-254mm)	0.015 in. (0.38mm)
Alt515	10-12 in. (254-305mm)	0.015 in. (0.38mm)
Alt417	8-10 in. (203-254mm)	0.017 in. (0.43mm)
Alt517	10-12 in. (254-305mm)	0.017 in. (0.43mm)
Alt519	12-14 in. (305-356mm)	0.019 in. (0.48mm)

Example: For an 8 to 10 in. (203 to 254mm) fan width and 0.013 (0.38mm) hole size, order Part No. alt413

Piston Lube

Specially Formulated to prevent materials from adhering to the piston rod, which become abrasive to the upper seals. Piston lube will break down any material that may accumulate in the oil cup and keep it from drying.



Part #	Description
--------	-------------

Alm-481.....	4 ounce bottle
--------------	----------------

Miscellaneous

Part No.	Description
----------	-------------

Alm-012.....	Hose coupling, 1/4"x1/4"
Alm-397.....	High Pressure Fl. Gauge
Alm-171.....	Lubriplate, 14 ounce individual
Alm-172.....	Lubriplate, 6 lb. Can
Alm-1037.....	Electrostatic discharge (ESD) wrist strap