



## Operating Instruction

Product model: DP6825,6830,6835 [diaphragm pump sprayer](#)

---



DP6825



DP6830,6835

Please read and keep this manual, Read carefully before attempting to assemble, install, operate or maintain the product described. Protect yourself and others by observing all safety information. Failure to comply with instructions could result in personal injury and/or property damage! Retain instruction for future reference.



Table of Contents

Warnings.....3-5

Component Identification .....6-7

Technical Data.....8

Operation.....9

Set up.....10

Start up.....11

**SPRAYING TECHNIQUE..... 12-13**

Install Tip & Guard on Spray Gun.....13

Tip Selection.....14-15

Clean up.....16-18

Troubleshooting.....19-21

Exploded view.....22

Appendices



Repair -Displacement pump



## Warnings



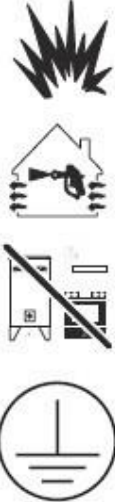



The following warnings are for the setup, use, grounding, maintenance, and repair of this equipment. The exclamation point symbol alerts you to a general warning and the hazard symbols refer to procedure-specific risks. When these symbols appear in the body of this manual, refer back to these Warnings. Product-specific hazard symbols and warnings not covered in this section may appear throughout the body of this manual where applicable.

### **WARNING**

	<p><b>FIRE AND EXPLOSION HAZARD</b></p> <p>Flammable fumes, such as solvent and paint fumes, in work area can ignite or explode. To help prevent fire and explosion:</p> <ul style="list-style-type: none"><li>● Do not spray flammable or combustible materials near an open flame or sources of ignition such as cigarettes, motors, and electrical equipment.</li><li>● Paint or solvent flowing through the equipment is able to result in static electricity. Static electricity creates a risk of fire or explosion in the presence of paint or solvent fumes. All parts of the spray system, including the pump, hose assembly, spray gun, and objects in and around the spray area shall be properly grounded to protect against static discharge and sparks. Use DINO-POWER conductive or grounded high-pressure <a href="#">airless paint sprayer</a> hoses.</li><li>● Verify that all containers and collection systems are grounded to prevent static discharge.</li><li>● Connect to a grounded outlet and use grounded extensions cords. Do not use a 3-to-2 adapter.</li><li>● Do not use a paint or a solvent containing halogenated hydrocarbons.</li><li>● Keep spray area well-ventilated. Keep a good supply of fresh air moving through the area. Keep pump assembly in a well ventilated area. Do not spray pump assembly.</li><li>● Do not smoke in the spray area.</li><li>● Do not operate light switches, engines, or similar spark producing products in the spray area.</li><li>● Keep area clean and free of paint or solvent containers, rags, and other flammable materials.</li><li>● Know the contents of the paints and solvents being sprayed. Read all Material Safety Data Sheets (MSDS) and container labels provided with the paints and solvents. Follow the paint and solvents manufacturer safety instructions.</li><li>● Fire extinguisher equipment shall be present and working</li></ul> <p>Sprayer generates sparks. When flammable liquid is used in or near the sprayer or for flushing or</p> <ul style="list-style-type: none"><li>● cleaning, keep sprayer at least 20 feet (6 m) away from explosive vapors.</li></ul>
	<p><b>ELECTRIC SHOCK HAZARD</b></p> <p>This equipment must be grounded. Improper grounding, setup, or usage of the system can cause electric shock.</p> <ul style="list-style-type: none"><li>● Turn off and disconnect power cord before servicing equipment.</li><li>● Use only grounded electrical outlets.</li><li>● Use only 3-wire extension cords.</li><li>● Ensure ground prongs are intact on power and extension cords.</li><li>● Do not expose to rain. Store indoors.</li></ul>







## Airless Paint Sprayer

  	<p><b>SKIN INJECTION HAZARD</b></p> <p>High-pressure spray is able to inject toxins into the body and cause serious bodily injury. In the event that injection occurs, get immediate surgical treatment.</p> <ul style="list-style-type: none"><li>● Do not aim the gun at, or spray any person or animal.</li><li>● Keep hands and other body parts away from the discharge. For example, do not try to stop leaks with any part of the body.</li><li>● Always use the nozzle tip guard. Do not spray without nozzle tip guard in place.</li><li>● Use DP-AIRLESS nozzle tips.</li><li>● Use caution when cleaning and changing nozzle tips. In the case where the nozzle tip clogs while spraying, follow the Pressure Relief Procedure for turning off the unit and relieving the pressure before removing the nozzle tip to clean.</li><li>● Do not leave the unit energized or under pressure while unattended. When the unit is not in use, turn off the unit and follow the Pressure Relief Procedure for turning off the unit.</li><li>● Check hoses and parts for signs of damage. Replace any damaged hoses or parts.</li><li>● Always engage the trigger lock when not spraying. Verify the trigger lock is functioning properly.</li><li>● Verify that all connections are secure before operating the unit.</li><li>● Know how to stop the unit and bleed pressure quickly. Be thoroughly familiar with the controls.</li></ul>
	<p><b>PRESSURIZED ALUMINUM PARTS HAZARD</b></p> <p>Use of fluids that are incompatible with aluminum in pressurized equipment can cause serious chemical reaction and equipment rupture. Failure to follow this warning can result in death, serious injury, or property damage.</p> <ul style="list-style-type: none"><li>● Do not use 1,1,1-trichloroethane, methylene chloride, other halogenated hydrocarbon solvents or fluids containing such solvents.</li><li>● Many other fluids may contain chemicals that can react with aluminum. Contact your material supplier for compatibility.</li></ul>
 	<p><b>EQUIPMENT MISUSE HAZARD</b></p> <p>Misuse can cause death or serious injury.</p> <ul style="list-style-type: none"><li>● Always wear appropriate gloves, eye protection, and a respirator or mask when painting.</li><li>● Do not operate or spray near children. Keep children away from equipment at all times.</li><li>● Do not overreach or stand on an unstable support. Keep effective footing and balance at all times.</li><li>● Stay alert and watch what you are doing.</li><li>● Do not leave the unit energized or under pressure while unattended. When the unit is not in use, turn off the unit and follow the Pressure Relief Procedure for turning off the unit.</li><li>● Do not operate the unit when fatigued or under the influence of drugs or alcohol.</li><li>● Do not kink or over-bend the hose.</li><li>● Do not expose the hose to temperatures or to pressures in excess of those specified by us.</li><li>● Do not use the hose as a strength member to pull or lift the equipment.</li></ul>



## Airless Paint Sprayer

 	<p><b>MOVING PARTS HAZARD</b></p> <p>Moving parts can pinch, cut or amputate fingers and other body parts.</p> <ul style="list-style-type: none"><li>● Keep clear of moving parts.</li><li>● Do not operate equipment with protective guards or covers removed.</li><li>● Pressurized equipment can start without warning. Before checking, moving, or servicing equipment, follow the Pressure Relief Procedure and disconnect all power sources.</li></ul>
	<p><b>BURN HAZARD</b></p> <p>Equipment surfaces can become very hot during operation. To avoid severe burns, do not touch hot equipment. Wait until equipment has cooled completely.</p>
	<p><b>TOXIC FLUID OR FUMES HAZARD</b></p> <p>Toxic fluids or fumes can cause serious injury or death if splashed in the eyes or on skin, inhaled, or swallowed.</p> <ul style="list-style-type: none"><li>● Please pay attention to know the specific hazards of the fluids before spraying.</li><li>● Store hazardous fluid in approved containers, and dispose of it according to applicable guidelines.</li></ul>
	<p><b>PERSONAL PROTECTIVE EQUIPMENT</b></p> <p>You must wear appropriate protective equipment when operating, servicing, or when in the operating area of the equipment to help protect you from serious injury, including eye injury, hearing loss, inhalation of toxic fumes, and burns. This equipment includes but is not limited to:</p> <ul style="list-style-type: none"><li>● Protective eyewear, and hearing protection.</li><li>● Respirators, protective clothing, and gloves as recommended by the fluid and solvent manufacturer.</li></ul>
	<p><b>MACHINE MAINTENANCE</b></p> <ul style="list-style-type: none"><li>● Cleaning the machine, parts every time after finished the paint work.</li><li>● The hydraulic oil should be changed after 300 hours works.</li><li>● The diaphragm should be changed after each 400 hours works.</li><li>● The screws connecting the front pump and the rear pump should be tightened diagonally.</li><li>● Please check every parts have screw on the machine very tightly before using machine. Especially the suction tube and high pressure hose.</li><li>● Please notice that the inlet valve, outlet valve, diaphragm, are easily broken parts, if the machine has worked many times, and the machine have some problem about the pressure, suction, please change them first, then check again.</li></ul>



Component Identification

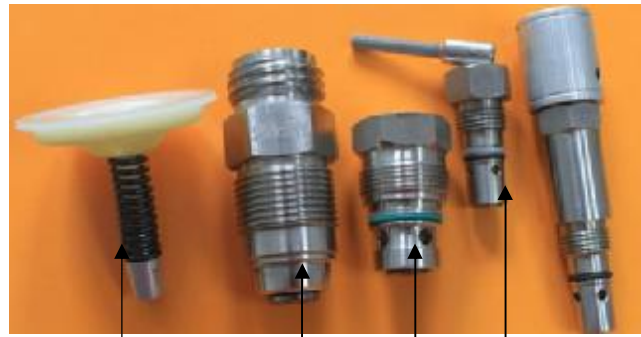
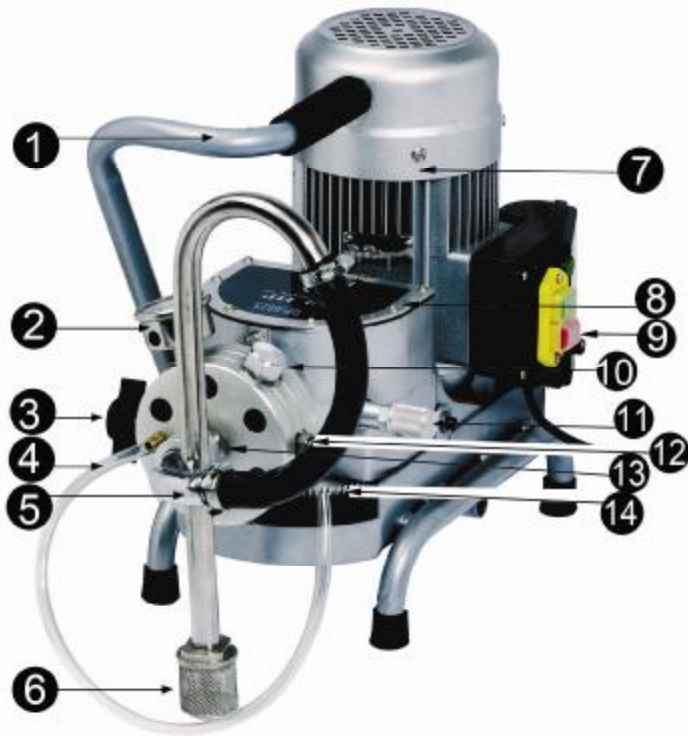

1	Handle	Carry machine.
2	Pressure gage	Easy for you to read the pressure you're spraying.
3	Prime/Spray valve	<ul style="list-style-type: none"> <li>● In PRIME position (pointing down) directs fluid to prime tube.</li> <li>● In SPRAY position (pointing forward) directs pressurized fluid to paint hose.</li> <li>● Automatically relieves system pressure in overpressure situations.</li> </ul>
4	Prime tube	Drains fluid in system during priming and pressure relief.
5	Suction tube	Draws fluid from paint pail into pump. (the tube must be screwed tightly otherwise air enter inside, so the pressure can't be reached your desired high pressure.)
6	Suction filter	Prevent the grains in the fluid to be sucked into the pump.



## Airless Paint Sprayer

7	Motor	Make the power for machine.
8	Oil cover	Prevent the oil leaked out. (please change the 46# hydraulic oil inside after 300 hours using)
9	On-off switch	Turns sprayer ON and OFF.
10	** Outlet valve	The valve control the fluid going out of the pump
11	Pressure regulator	Increases (clockwise) and decreases (counter-clockwise) fluid pressure in pump, hose, and spray gun.
12	Hose Connector	Connect the high pressure hose with airless spray gun.
13	** Inlet valve	The valve control the fluid sucking into the pump
14	Belt	To reduce the power from Motor, and supply the right power to the machine.
15(1)	**Diaphragm	Moved by the piston inside, and pump out the fluid.
15	High pressure hose	Transports high-pressure fluid from pump to spray gun.
16	** Tip guard / Safety guard	Reduces risk of fluid injection injury.
17	** Spray gun tip	<ul style="list-style-type: none"><li>• Atomizes fluid being sprayed, forms spray pattern and controls fluid flow according to hole size.</li><li>• Reverse unclogs plugged tips without disassembly.</li></ul>
18	Gun trigger safety lever / lock	Prevents accidental triggering of spray gun. (please lock the spray gun when not using/repair/clean etc)
19	Airless spray gun	Dispenses fluid.
20	Gun fluid inlet fitting	Threaded connection for paint hose.

(the parts marked with \*\* are easily worn parts.)



## Technical Data

Model number.	<b>DP6825</b>	<b>DP6830</b>	<b>DP6835</b>
Type	Electric & diaphragm	Electric & diaphragm	Electric & diaphragm
Pressure controlling	Mechanical	Mechanical	Mechanical
Power	1100w	1500w	1500w
Max.pressure (bar)	250bar/3630psi	250bar/3630psi	250bar/3630psi
Max.delivery (L/min)	2.5 L/min	3.0 L/min	3.5 L/min
Max.tip size (inch)	0.021"	0.025"*1 or 0.015"*2	0.029"*1 or 0.017"*2
Max.hose length (m)	60m	60m	90m
Hose operating pressure	250bar/3630psi	250bar/3630psi	250bar/3630psi
Hose exploded pressure	800bar/11620psi	800bar/11620psi	800bar/11620psi
Electric Motor	Induction motor (brushless)	Induction motor (brushless)	Induction motor (brushless)
Motor speed (rpm)	2880 rpm	2880 rpm	2880 rpm
Spraying distance (cm)	40 - 50cm	40 - 50cm	40 - 50cm
Paint viscosity	Medium (less than 120s)	Medium to high	Medium to high
both water-based & oil-based?	Yes	Yes	Yes
Net weight	31.50KGS	44KGS	47KGS
Gross weight	33.50KGS	46KGS	50KGS
Carton size	51x33.5x56 cm	64x56x75 cm	64x56x75 cm
Contents in package	<a href="#">Airless paint sprayer</a> , airless spray gun with 517 tip, 1/4*15m hose, repair kit, manual.	<a href="#">Airless paint sprayer</a> , one airless spray gun with 525 tip, one 1/4*15m hose, 45cm extension pole, repair kit, manual.	<a href="#">Airless paint sprayer</a> , <b>two</b> airless spray guns (529 tips), <b>two</b> 1/4*15m hoses, <b>two</b> 45cm extension poles, repair kit, manual.

(The standard package doesn't include all the easily worn parts, but has diaphragm inside. Inlet valve / Outlet valve / extension pole are available if you pay extra cost)





# Operation

## Trigger Lock

Always engage the trigger lock when you stop spraying to prevent the gun from being triggered accidentally by hand or if dropped or bumped.



3. Hold gun firmly to side of pail. Trigger the gun to relieve pressure.



4. Engage trigger lock.



## Pressure Relief Procedure

Follow this **Pressure Relief Procedure** whenever you stop spraying and before cleaning, checking, servicing, or transporting equipment.

1. Turn power switch OFF and unplug power cord.



2. Turn Prime/Spray valve to PRIME to relieve pressure.



**NOTE:** Leave Prime/Spray valve in the PRIME position until you are ready to spray again. If you suspect the spray tip or hose is clogged or that pressure has not been fully relieved after following the steps above, **VERY SLOWLY** loosen tip guard retaining nut or hose end coupling to relieve pressure gradually, then loosen completely. Clear hose or tip obstruction. Read Unclogging Spray Tip instructions in the Sprayer or Gun Operation manual.



# Setup

**1. Prepare the paint according to the manufacturer's recommendations**

This is probably one of the most important steps toward trouble-free spraying!

Remove any skin that may have formed on the top of the paint. If necessary, thin the paint. Finally, strain the paint through a fine nylon mesh filter bag (available at most paint dealers) to remove particles that could clog the spray tip

**2. Unscrew tip and guard assembly from gun.**



**3. Uncoil hose and connect one end to gun. Use two wrenches to tighten securely and tightly.**



**4. Connect other end of hose to sprayer.**

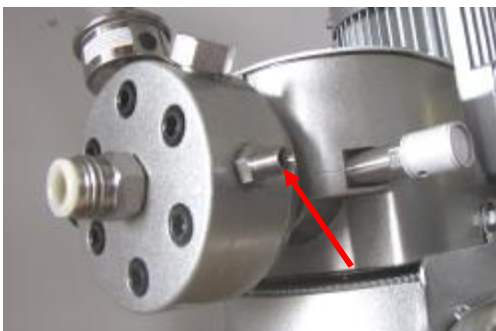

**5. Check the hydraulic oil level.** Unscrew the cover 7#, The oil should be 10mm from the top of the plate. If the oil is low, fill as necessary low viscosity hydraulic oil (**#46 hydraulic anti-wearing oil**); Install back the 7# cover. [DP6825 / 6830 / 6835: 1.0L (10mm distance to the top level)]

**6. Check the electrical service** Be sure the electrical outlet is properly grounded. You can use up to 100 foot (30m) of 3 wire, extension cord. Longer extension cords may affect the sprayer performance. Use more spray hose, not longer extension cords

**7. Plug in the sprayer.** First be sure the ON/OFF switch is OFF and the pressure control valve is turned fully counterclockwise. Plug the sprayer into a grounded outlet that is at least 3 m away from the spray area to reduce the chance of a spark igniting, spray vapors or dust particles.



**Pressure regulator valve**

**Clockwise: stronger / Higher pressure**



**Counter clockwise: weaker / Lower pressure**



(For item DP6825 / DP6825B / DP6830 / DP6835 )



# Startup

1. First be sure the ON/OFF switch is OFF.
2. Adjust Pressure Regulator Valve 9# counter clockwise to lowest pressure.
3. Place the suction hose 3# into the coating barrel.
4. Pull up the Prime Spray Valve 2# into **A**: Prime position. (see picture below)



5. Place the suction hose 3# into the coating barrel.



6. Plug sprayer in a grounded cable socket.

7. Switch ON the machine.



8. Turn the Pressure Regulator Valve 9# clockwise, till the fluid is circulating in the prime tube (4#)

9. Turn power switch OFF.



10. Transfer suction tube to paint pail and submerge suction tube in paint.

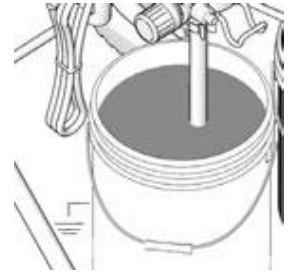

11. Turn power switch ON.



12. When you see paint coming out of prime tube:
  - (1). Point gun into waste pail.
  - (2). Unlock gun trigger lock.
  - (3). Pull and hold gun trigger.
  - (4). Turn Prime/Spray valve to **B**: SPRAY position.

13. Continue to trigger gun into waste pail until you see only paint coming out of gun.

14. Release trigger. Engage trigger lock.

15. Transfer prime tube to paint pail and clip prime tube to suction tube.



## SPRAYING SPRAYING TECHNIQUE

1. The key to a good paint job is an even coating over the entire surface. With spray painting, this is done by using even strokes, with your arm moving at a constant speed and keeping the spray gun a constant distance from the surface.

2. As much as possible, keep the spray gun at right angles to the surface. This means moving your entire arm back and forth rather than just flexing your wrist.

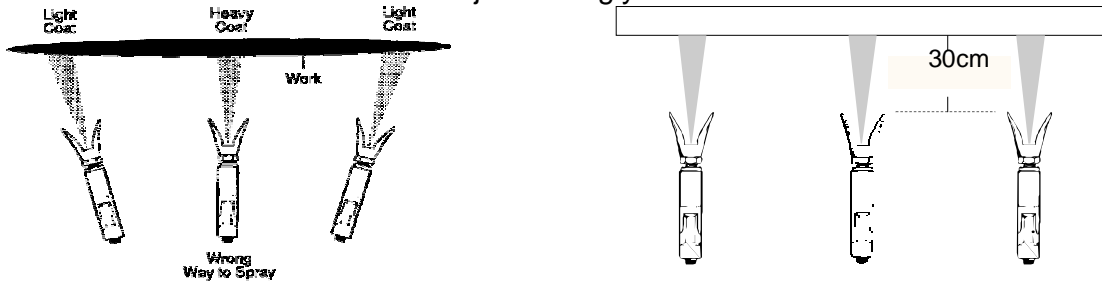

3. Keep the spray gun perpendicular to the surface, otherwise one end of the pattern will be thicker than the other.

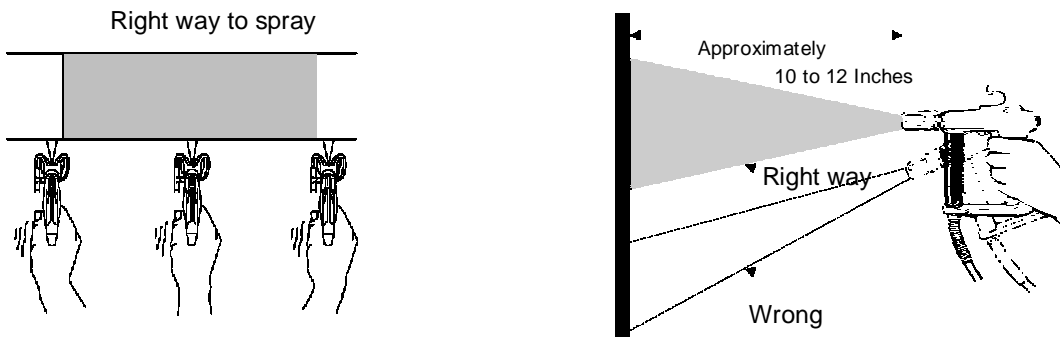

4. In most cases, the best spraying distance is 10 to 12 inches (25-30cm) between the spray tip and the surface.

5. The spray gun should be triggered off at the end of each stroke and on again at the beginning of the next. This avoids paint buildup at the end of the stroke which may result in runs and sags. Triggering at the end of the stroke also saves paint and results in a better looking job. (See picture below)

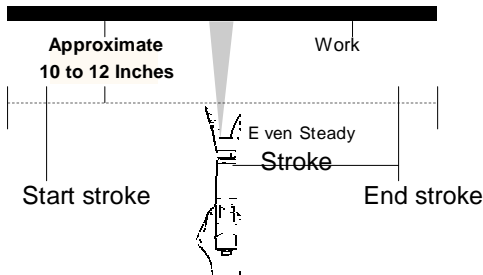

6. The correct speed for moving the gun will allow a full, wet coating to be applied without runs or sags. Lapping each stroke about 40% over the previous stroke produces uniform paint thickness. Spraying in a uniform pattern alternately from right to left and then left to right, provides a professional finish. (See picture on the right)

One way to do this is to point the spray tip at the edge of the last stroke before triggering the gun on.

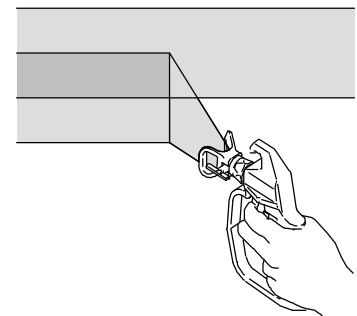



7. When taking a short break from painting (up to 1 hr.), lock the spray gun trigger **OFF**, reduce pressure to its minimum (zero) setting and set the unit to **A: Prime** position . Turn sprayer off and unplug. Refer to Pressure Relief Procedure.

8. For interior corners, such as on a bookcase or inside a cabinet, aim the gun toward the center of the corner to spray. By dividing the spray pattern this way, the edges on both sides are sprayed evenly.

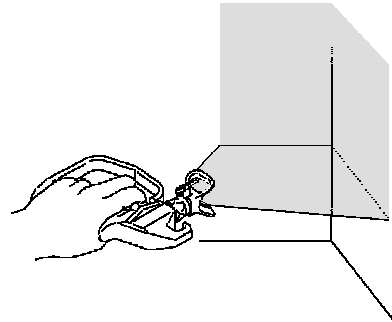

### Install Tip & Guard on Spray Gun

1. Engage trigger lock.



2. Verify tip and guard parts are assembled in order shown.

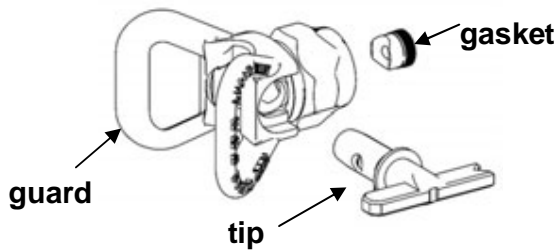

3. Use tip to align seat

Tip must be pushed in guard all the way into guard

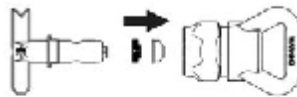

4. Screw tip and guard assembly on gun. Tighten retaining nut.





## Tip Selection

### Selecting Tip Hole Size

Tips come in a variety of hole sizes for spraying a range of fluids. Your sprayer includes an 0.017 in (0.43 mm) tip or maybe 0.019" (0.48mm) for use in most spraying applications.

Use the following

table to determine the range of recommended tip hole sizes for each fluid type. If you need a tip other than the one supplied, see the **Reversible Tip Selection Chart**

### HINTS:

- As you spray, the tip wears and enlarges. Starting with a tip hole size smaller than the maximum will allow you to spray within the rated flow capacity of the sprayer.
- Maximum tip hole sizes supported by the sprayer:
  - DP6825 : 0.021 inch .
  - DP6830 : 0.025 inch .
  - DP6835 : 0.029 inch( one gun)  
0.017 inch( two guns)

## Choosing the Correct Tip

Consider coating and surface to be sprayed. Make sure you use best tip hole size for that coating and best fan width for that surface.

### Tip Hole Size

Tip hole size controls flow rate - the amount of paint that comes out of the gun.

### HINTS:

- Use larger tip hole sizes with thicker coatings and smaller tip hole sizes with thinner coatings.
- Maximum tip hole sizes supported by sprayer:
  - DP6825 : 0.021 inch .
  - DP6830 : 0.025 inch .
  - DP6835 : 0.029 inch( one gun)  
0.017 inch( two guns)
- Tips wear with use and need periodic replacement.

### Fan Width

Fan width is the size of the spray pattern, which determines the area covered with each stroke. Narrower fans deliver a thicker coat, and wider fans deliver a thinner coat.

### HINTS:

- Select a fan width best suited to the surface being sprayed.
- Wider fans allow provide better coverage on broad, open surfaces.
- Narrower fans provide better control on small, confined surfaces.

Tip Hole Size	Coatings				
	Stains	Enamels	Primers	Interior Paints	Exterior Paints
0.015 in. (0.38mm)	<b>P</b>	<b>P</b>	<b>P</b>	<b>P</b>	
0.017 in. (0.43mm)			<b>P</b>	<b>P</b>	<b>P</b>
0.019 in. (0.48mm)			<b>P</b>	<b>P</b>	<b>P</b>
0.021 in. (0.53mm)					<b>P</b>
0.023 in. (0.58mm)					<b>P</b>
0.025 in. (0.63mm)					<b>P</b>



## Understanding Tip Number

The last three digits of tip number contain information about hole size and fan width on surface when gun is held 12 in. (30.5 cm) from surface being sprayed.

First digit when doubled = approximate fan width

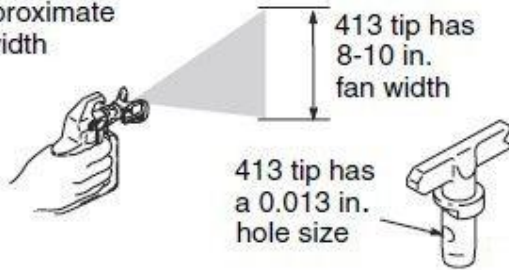

Last two digits = tip hole size in thousands of an inch

Tip Part No.	Fan Width 12 in. (305 mm) from surface	Hole Size
311	6 - 8 in. (152 - 203 mm)	0.011 in. (0.28 mm)
411	8 - 10 in. (203 - 254 mm)	0.011 in. (0.28 mm)
313	6 - 8 in. (152 - 203 mm)	0.013 in. (0.33 mm)
413	8 - 10 in. (203 - 254 mm)	0.013 in. (0.33 mm)
415	8 - 10 in. (203 - 254 mm)	0.015 in. (0.38 mm)
515	10 - 12 in. (254 - 305 mm)	0.015 in. (0.38 mm)
417	8 - 10 in. (203 - 254 mm)	0.017 in. (0.43 mm)
517	10 - 12 in. (254 - 305 mm)	0.017 in. (0.43 mm)

## Reversible Tip Selection Chart

Orifice Size (inches)	Fan Width - Inches					Flow Rate (gpm)	Application
	4" - 6" Fan	6" - 8" Fan	8" - 10" Fan	10" - 12" Fan	12" - 14" Fan		
.011"	211	311	411			0.12	Stain or Lacquer
.013"	213	313	413	513	613	0.16	
.015"	215	315	415	515	615	0.22	Oil Base Paint
.017"	217	317	417	517	617	0.25	Latex Paint
.019"	219	319	419	519	619	0.33	/Acrylic/Enamel.
.021"		321	421	521	621	0.41	
.023"				523	623	0.49	Heavy Latex
.025"				525	625	0.57	

## Important things to know about tip wear

It's important to replace a tip when it becomes worn, this ensures you'll have a precise spray pattern, maximum productivity and a quality finish. When tip wears, the hole(orifice) size increases and spray pattern width decreases.



Tip life varies by coating, Extend tip life by spraying at the lowest pressure that breaks up(atomizes)the coating into a complete spray pattern.

### Recommend tip replacement

Latex: After 4000~5000 m<sup>2</sup>



## CLEANUP

As with all spray equipment, your sprayer must be cleaned properly or it will not operate properly. Clogged valves and filters are the most common causes of problems. If followed, these guidelines will insure trouble free performance from your sprayer.

1. Lock the gun and reduce the pressure. Turn the sprayer to prime A and shut it off. Unplug sprayer. Leave the suction set in the paint. Refer to pressure relief procedure

2. Remove suction tube from paint and hold it above a bucket of water or solvent. Leave the return tube aimed into the paint bucket.

3. Set PRESSURE CONTROL KNOB **counter** clockwise back to minimum pressure. Trigger gun to relieve pressure and lock gun.

4. Increase PRESSURE CONTROL KNOB clockwise to about 1/3 to 1/2 maximum pressure. This will draw the remaining paint in the suction tube through the pump and down the return tube into the paint bucket.

5. Place suction tube and return tube in container of water or compatible solvent.

6. Remove spray tip and guard, washer, and let soak in warm water or appropriate solvent.

7. Increase pressure to about 1/2 maximum pressure and let circulate for 2-3 minutes to flush paint out of the pump, suction tube and return tube.

8. To save paint left in the hose, carefully trigger the gun (with spray tip removed) against the inside of the paint container. Reduce PRESSURE CONTROL KNOB to zero, then

turn PRIMING KNOB to SPRAY B

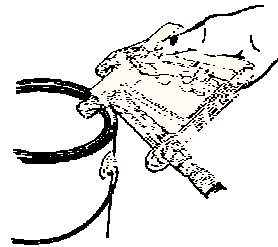

### Save Paint Back To Paint Can

9. Increase PRESSURE CONTROL KNOB again until paint starts to flow into the bucket. As soon as the water or solvent starts to come into the bucket, release the trigger.

10. Change to clean water or solvent and continue circulating for another 5 minutes to thoroughly clean the hose, pump and spray gun.

11. Reduce pressure and turn to prime A. Trigger gun. Lock gun and shut sprayer off.

12. Remove spray gun from paint hose, using two adjustable wrenches. Remove filter housing from gun. Place gun and filter assembly into a container of water or solvent to soak. Cover paint container and set it aside.

13. Clean spray tip and gun filter with a soft brush. Reassemble spray tip in cleaning position. (Arrow points to back of the gun.)

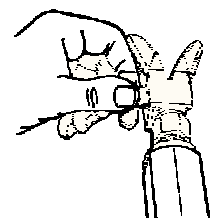
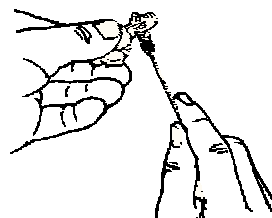





14. Attach paint hose to gun, tighten with two wrenches



15. Turn the unit on and unlock gun trigger. Turn to Spray B and point gun to side of cleaning bucket.

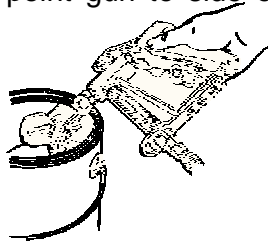

16. Trigger gun and gradually turn pressure knob **clock- wise** to 1/2 pressure. Continue for approximately 30 seconds

17. Release and lock trigger, reduce pressure, turn to prime A . Turn unit off.

18. Remove tip assembly. Raise the suction set above the cleaning solution. Turn unit on, turn to spray increase pressure and allow suction tube to run dry.

19. Remove large suction tube from inlet valve, See and point gun into cleaning bucket,

23. Remove and clean suction set filter in clean water or solvent with soft brush. Reassemble.

Reduce pressure about 1/2, unlock gun trigger gun until hose is pumped dry.

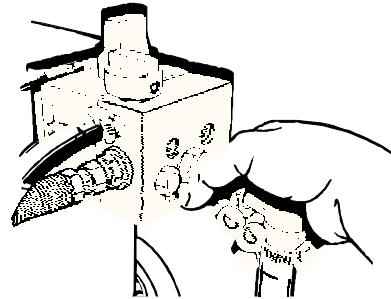

20. Lock gun, reduce pressure and turn Prime/Spray Knob to prime A

21. Lay unit back on handle so inlet valve is facing upward. Clean threads of inlet valve with a damp cloth. Fill inlet valve with light household oil. Slowly increase pressure to distribute the oil through the pump. Turn Prime/Spray Knob from prime A to spray B to distribute oil. Replace large suction tube to inlet valve.

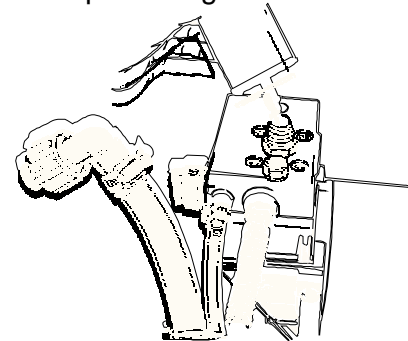

22. Turn Prime/Spray Knob to prime A , reduce pressure, shut sprayer off. Unplug sprayer. Refer to Pressure Relief.

24. Wipe entire unit, hose and gun with a damp cloth to remove accumulated paint.

## CLEANING VALVES

Follow these procedures when encountering problems indicated in the trouble shooting section.

## Removing and Cleaning Inlet Valve

1. Be sure sprayer is off.
2. Using a 27 millimeter socket or box end wrench, remove the inlet valve assembly.



Remove  
Inlet Valve

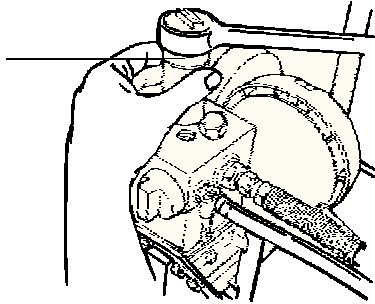

3. Test movement of the valve by pushing on it from the open end of the valve housing with the eraser end of a pencil or a screwdriver. It should move about 1/16 inch. If it doesn't move, it is probably full of dry paint or other debris and should be cleaned or replaced.

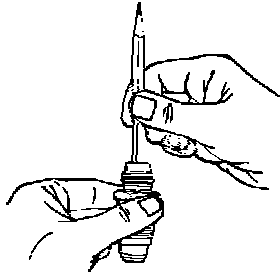

4. Thoroughly clean the valve assembly with solvent and brush

5. A properly seated valve filled with water and held vertically will not drip out the bottom of the valve. If you have properly cleaned the valve

and water drips out the bottom, the valve is worn and needs to be replaced

6. Install cleaned or new valve in the pump block and then fill the valve with light oil or solvent.

7. If none of the above steps work, see Troubleshooting .

## Cleaning and Servicing Outlet Valve

It may be occasionally necessary to remove and clean the outlet valve or replace normal wear parts inside the valve.

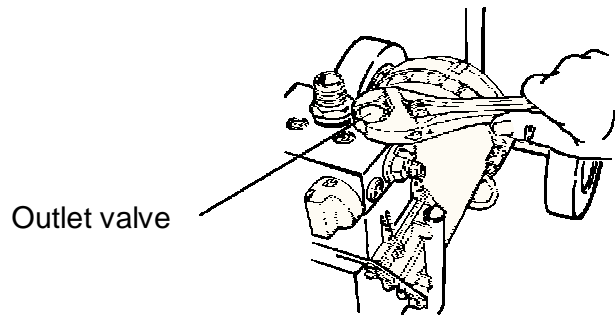

If possible, leave the copper washer under the cap in place. At least be sure to replace it with the same side up. (The top will show the imprint of the end cap, while the bottom should be perfectly flat to match seat in the pump casting.) See Paint Pump Assembly.

## Machine Maintenance

- Cleaning the machine, parts every time after finished the paint work.
- Replace the 46# hydraulic oil inside the rear pump body after 300 hours of work to reduce equipment wear.
- The diaphragm should be changed after each 400 hours works.
- The screws connecting the front pump and the rear pump should be tightened diagonally.
- Please check every parts have screw on the machine very tightly before using machine. Especially the suction tube and high pressure hose.
- Please notice that the inlet valve, outlet valve, diaphragm, are easily broken parts, if the machine has worked many times, and the machine have some problem about the pressure, suction, please check them first, then check again
- Clean the motor cooling fan protection guard and the finned motor casing periodically to ensure the maximum cooling.



## Troubleshooting

<b>Problem</b>	<b>Cause</b>	<b>Solution</b>
Power switch is on and sprayer is plugged in, but motor does not run, and pump does not cycle.	Pressure is set at zero pressure.	Turn pressure control knob clockwise to increase pressure setting.
	Motor or control is damaged.	Please contact with your supplier or Ningbo Dino-power Machinery Co.,ltd directly.
	Electric outlet is not providing power.	<ul style="list-style-type: none"><li>• Try a different outlet or plug in something that you know is working to test outlet.</li><li>• Reset building circuit breaker or replace fuse.</li></ul>
	Extension cord is damaged.	Replace extension cord.
	Sprayer electric cord is damaged.	Check for broken insulation or wires. Replace electric cord if damaged.
	Paint and/or water is frozen or hardened in pump.	<p>Unplug sprayer from outlet. If frozen do NOT try to start sprayer until it is completely thawed or you may damage the motor, control board and/or drivetrain.</p> <p>Make sure power switch is OFF. Place sprayer in a warm area for several hours. Then plug in power cord and turn sprayer ON. Slowly increase pressure setting to see if motor will start.</p> <p>If paint is hardened in sprayer, pump packings, valves, drivetrain or pressure switch may need to be replaced. Please contact with your supplier or contact with us directly.</p>



## **Airless Paint Sprayer**

<b>Problem</b>	<b>Cause</b>	<b>Solution</b>
Sprayer starts up but does not draw in paint.	Unit will not prime or has lost prime	Re prime Unit
	No paint. Suction tube not totally immersed in paint	Immerse suction tube in paint
	Suction set filter clogged.	Clean filter.
	Hopper screen clogged	Clean screen.
	Suction tube loose at inlet valve	Clean connection and tighten
	Inlet valve stuck	Clean inlet valve
	Outlet valve stuck.	Clean outlet valve Replace any worn parts.
	Inlet valve worn or damaged.	Clean or replace
Pump cycles but does not build up pressure.	Pump is not primed.	Prime pump.
	Inlet screen is clogged .	Clean debris off inlet screen and make sure suction tube is immersed in fluid.
	Suction tube is not immersed in paint.	Make sure suction tube is immersed in paint.
	Suction tube is leaking.	Tighten suction tube connection. Inspect for cracks or vacuum leaks. If cracked or damaged, replace suction tube.
	Prime/Spray Valve is worn or obstructed with debris.	Clean the valve or replace a new one.
	Pump check ball is stuck.	Remove outlet fitting and clean outlet check ball.
Pump cycles, but paint only dribbles or spurts when spray gun is triggered.	Pressure is set too low.	Slowly turn Pressure Control Knob clockwise to increase pressure setting which will turn motor on to build pressure.
	Spray tip is clogged.	Unclog spray tip
	Fluid filter is clogged.	Clean or replace fluid filter
	Spray gun fluid filter is clogged.	Clean or replace gun fluid filter,
	Spray tip is too large or worn.	Replace tip.



## **Airless Paint Sprayer**

<b>Problem</b>	<b>Cause</b>	<b>Solution</b>
Sprayer draws up paint but drops away when gun is opened	Worn spray tip	Replace with new tip.
	Suction set filter clogged	Clean filter.
	Optional hopper screen clogged	Clean screen
	Gun or spray tip filter plugged.	Clean or replace filter. Keep extra filters on hand
	Paint too heavy or coarse.	Thin or strain paint
	Dirty or worn outlet valve assembly.	Clean or replace
	Inlet valve worn or damaged.	Replace valve
Tip assembly leaks	Assembled incorrectly	Check assembly.
	Worn seal.	Replace seal.
Spray gun won't spray	Spray tip, gun filter or tip clogged	Clean spray tip
	filter plugged	Clean or replace gun or filter.
	Spray tip in Clean position	Put tip in Spray position
Paint tailing.	Pressure is set too low.	Increase pressure
	Gun, tip, or suction filter plugged.	Clean filters
	Suction tube loose at inlet valve	Tighten suction tube fitting
	Tip worn.	Replace tip
	Paint too thick	Thin paint
Thermal overload tripped	Motor over heated.	Allow to cool 15 to 30 min.
	Paint build up on motor.	Clean paint from motor.
	Unit sitting in hot sun.	Move to a shady location
Paint is coming out of pressure control switch.	Pressure control switch is worn.	Change a new one or contact with your supplier
Paint leaks down outside of pump..	Pump packings are worn	Replace pump packings.
Fan pattern varies dramatically while spraying. OR Sprayer does not turn on promptly when resuming spraying.	Pressure control switch is worn and causing excessive pressure variation.	Please contact with your supplier.

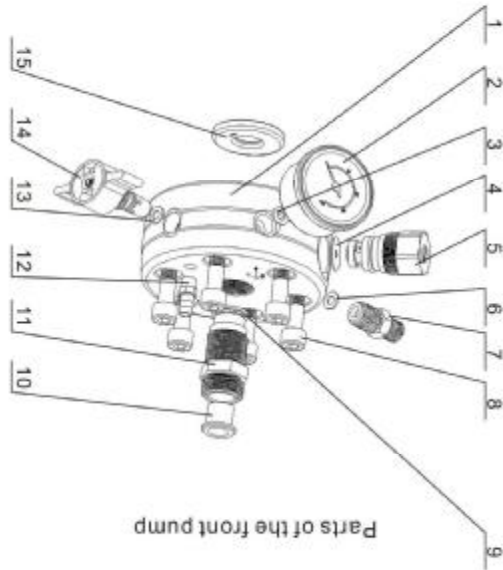

Parts of the front pump

S/N	Name	Qty	S/N	Name	Qty
1	Front pump body	1	9	Inlet valve gasket	1
2	Pressure gauge	1	10	Inlet valve sealing gasket	1
3	Pressure gauge sealing gasket	1	11	Inlet valve assembly	1
4	Outlet valve gasket	1	12	Tower connector	1
5	Outlet valve	1	13	Prime spray valve gasket	1
6	Outlet connector gasket	1	14	Prime spray valve	1
7	Outlet connector	1	15	Four stems of the diaphragm	1
8	Hose	6			

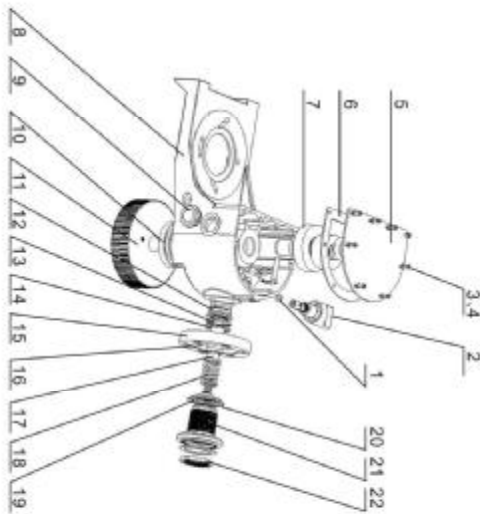

Parts of the back pump

S/N	Name	Qty	S/N	Name	Qty
1	Pressure regulating valve gasket	1	12	Piston suit	1
2	Pressure regulating valve assembly	1	13	Washer	1
3	M4 Screw	8	14	Four fluorine ring	1
4	φ 4 Flat screw	8	15	Ring flange	1
5	Back pump body cover	1	16	Piston	1
6	O-ring gasket	1	17	Piston spring holder	1
7	Partially o-ring assembly	1	18	Piston spring	1
8	Back pump body	1	22	Diaphragm assembly	1
9	O-ring	1	21	Connector of the front and back pump body	1
10	O-ring gasket of bearing	1	19	Seal gasket	1
11	Pulley	1	20	Locknut	1